

Engineered to provide safe, stepped-down voltage for machine tool and industrial control circuits. This transformer isolates control wiring from main power and lighting sources, reducing electrical noise and enhancing system safety.

Compact in design, it fits easily into limited panel spaces while delivering stable performance under demanding conditions. Suitable for use in control panels, automation systems, and various industrial equipment.



Specifications

Complies with IEC/EN 61558-2 standards. **CE**

Input Voltage 50/60Hz	Output Voltage	Model	Power	Weight (kg) (+/-)
0-230-415VAC	0-12-24-48-110-220VAC	MCT-50	50VA	1.3
		MCT-100	100VA	1.7
		MCT-250	250VA	3.8
		MCT-500	500VA	6.1
		MCT-1200	1200VA	12.0

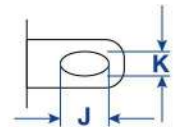
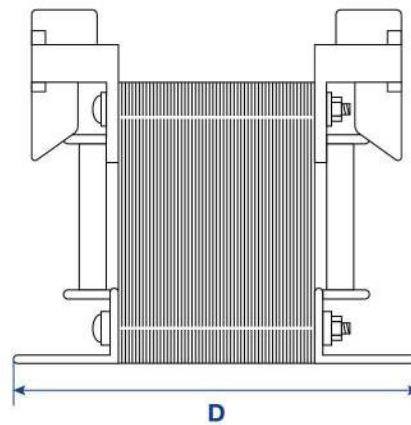
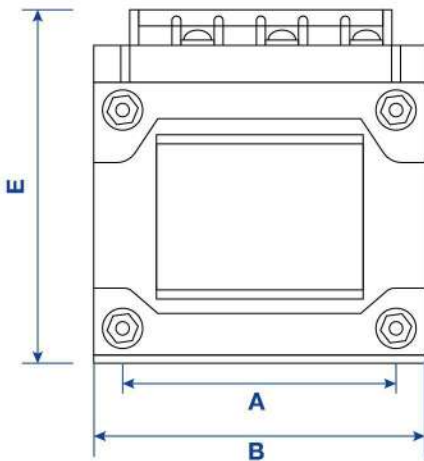

Dimensions

(mm) (+/-)

Model	B	D	E	A	K x J
MCT-50	76	76	85	64	5.5 x 11
MCT-100	76	76	97	64	5.5 x 11
MCT-250	114	114	105	96	7.9 x 20.5
MCT-500	114	114	135	96	7.9 x 20.5
MCT-1200	133	133	160	104.5	7.9 x 20.5